

**WARNING:** ALWAYS INSTALL FIXTURES ACCORDING TO NATIONAL ELECTRICAL CODE (NEC) AND LOCAL CODES. FAILURE TO DO SO WILL VOID THE WARRANTY AND COULD CAUSE DAMAGE TO THE FIXTURE OR MAY RESULT IN PERSONAL INJURY.

This information deals with structures supplied by Techlight along with certain safety issues. It is **NOT** a comprehensive description of how to install these structures. Installation contractors must be relied upon for equipment and practices that meet the conditions of each job location. Techlight cannot be responsible for any damage that may occur during or after installation, or for any structure that has been modified by the purchaser or that is used in some way other than our application recommendations.

**⚠ CAUTION:** MAKE CERTAIN POWER SUPPLY IS DISCONNECTED DURING INSTALLATION!

**HARDWARE KITS:** Each mounting option is provided with a Hardware Kit specific to that mounting option.

**CTLARM:** (2) flat washers, (2) lock washers, (2) 3/8"-16 x 1-1/4" hex bolts, (2) internal pole nut plate (for Techlight VSA or SSA drill pattern) (2) 5/16-18x1 Hex SKT Cap Screws

**NOTE:** RPASSA must be ordered for mounting on round poles.

**CTLISM:** (2) flat washers, (2) lock washers, (2) 3/8"-16 x 1-1/4" hex bolts, (2) internal pole nut plate (for Techlight SSA drill pattern)

**CTL2AF:** (2) flat washers, (2) lock washers, (2) 3/8"-16 x 1-1/4" hex bolts, (2) internal pole nut plate (for Techlight VSA or SSA drill pattern) CTL2AF mounts on STD 2" pipe (2-3/8 OD) Tenon

### TOOLS REQUIRED FOR ASSEMBLY

(Provided By Others): 1/4" Hex Key [1/4" Allen Wrench], T15 Torx Driver, T20 Torx Driver, 1/8" Hex Key

**IMPORTANT:** TURN ELECTRICITY OFF AT THE CIRCUIT BREAKER BEFORE INSTALLING OR PERFORMING MAINTENANCE ON FIXTURE.

### INSTALLATION USING THE CTLARM

1. Remove the wire access cover on the CTLARM to expose the mounting holes used to mount the arm to the pole.
2. Position the nut plate inside the pole so that the mounting holes in the nut plate and pole line up with the mounting holes in the CTLARM (FIGURE 1). If mounting on a round pole use the RPASSA, position the round pole adapter between the pole and CTLARM
3. Secure the mounting arm to the pole using the (2) flat washers, (2) lock washers, (2) 3/8"-16 x 1-1/4" hex bolts. Torque bolts to 18-25 ft/lbs minimum.
4. Pull the fixture whip into the wiring chamber of the mounting arm and slide the fixture onto the slide mount adapter (FIGURE 2). Insert and tighten the (2ea) 5/16-18 hex socket cap screws using 1/4" Hex Key. Tighten cap screws to 12-15 ft. lbs. torque.
5. Access the LED driver compartment for servicing by removing the two #10-24 hex socket cap screws located on the driver access door (FIGURE 3). There is no need to enter the luminaires LED driver compartment during normal installation.
6. Erect the pole.

**FIGURE 1** CTLARM - REMOVE COVER FOR MOUNTING ACCESS

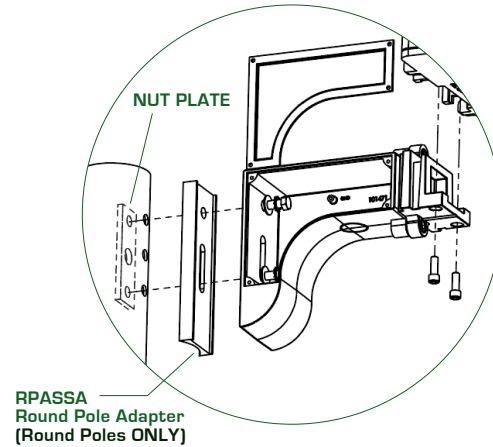

**FIGURE 2** CTLARM - SLIDE FIXTURE ONTO MOUNT ADAPTER

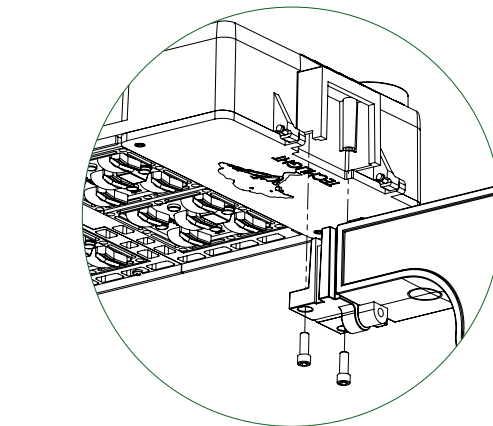

**FIGURE 3** CTLARM - ACCESS LED DRIVER COMPARTMENT

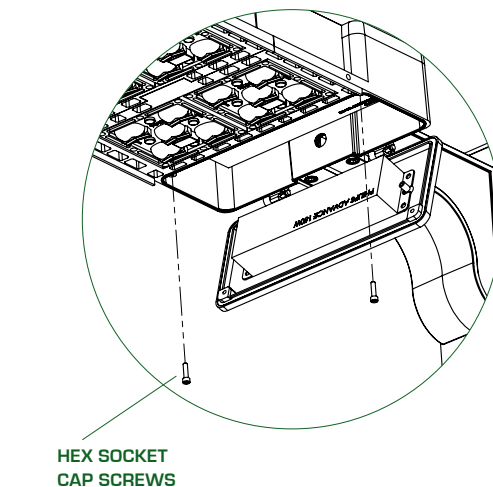

**NOTE:** Always verify the voltage at which the incoming power is supplied. The Cutlass fixture is available in two separate models; one auto-ranging from 100V~300V and another model for 347V~480V operation.

7. Connect the power supply to the whip inside the CTLARM according to local code and the National Electric Code (NEC). Replace the wire access cover of the CTLARM.

### INSTALLATION USING THE CTLSM

1. CTLSM requires power supply connection inside of the pole.
2. Secure the CTLSM to the pole using the set screws provided (FIGURE 4).
3. Pull the fixture whip through the CTLSM and into the pole. Slide the fixture onto the slide mount adapter onto the fixture side of the CTLSM (FIGURE 2). Insert and tighten the (2ea) 5/16-18 hex socket cap screws using ¼" Hex Key. Tighten cap screws to 12-15 ft./lbs. torque.

### INSTALLATION USING THE CTLTH

1. CTLTH requires power supply connection inside of the pole.
2. Secure the CTLTH to the pole using the set screws provided (FIGURE 5).
3. Pull the fixture whip through the CTLSM and into the pole. Slide the fixture onto the slide mount adapter onto the fixture side of the CTLSM (FIGURE 2). Insert and tighten the (2ea) 5/16-18 hex socket cap screws using ¼" Hex Key. Tighten cap screws to 12-15 ft./lbs. torque.

### INSTALLATION USING THE CTL2AF

1. The CTL2AF was designed to mount onto a 2-3/8" OD tenon (2" Nominal Pipe). Place 2AF on pole tenon and orient to desired position. Tighten set screws lightly.
2. Pull the fixture whip through the CTL2AF and slide the fixture onto the slide mount adapter onto the fixture side of the CTL2AF (see Fig F). Insert and tighten the (2ea) 5/16-18 hex socket cap screws using ¼" Hex Key. Tighten cap screws to 12-15 ft. lbs. torque. Adjust the fixture angle and tighten the adjustment bolt on the side of the CTL2AF.
3. Remove 2AF wire access cover and connect to power supply leads. Tilt fixture to desired aiming angle & tighten hex bolt to lock tilt.
4. Rotate the fixture to the final desired orientation and secure the CTL2AF onto the tenon by tightening the (4) set screws

**DO NOT TILT CTL MORE THAN 45 DEGREES UPWARD FROM HORIZONTAL!**

**FIGURE 4** CTLSM MOUNT

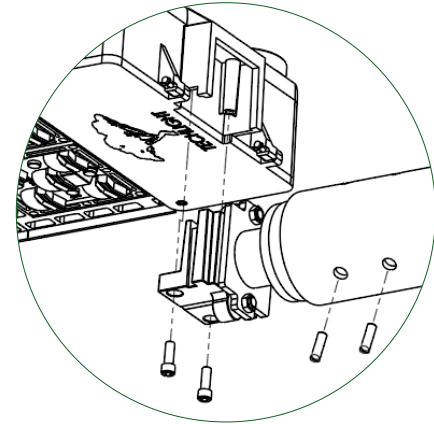

**FIGURE 5** CTLTH MOUNT

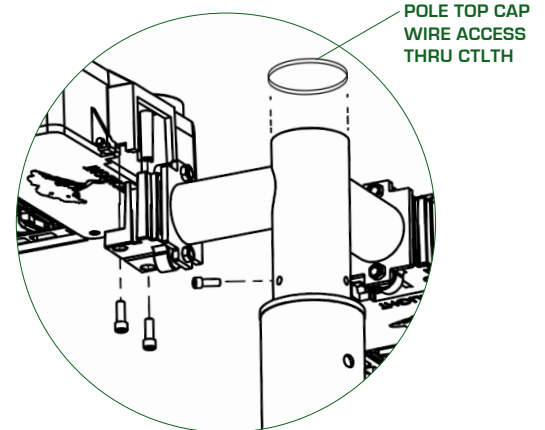

**FIGURE 6** CTL2AF MOUNT

