



Catalog Number	
Project	Type

## Features & Specifications

### Construction

Constructed with a die cast aluminum housing. A tempered glass lens protects the optical system. Gasketed side hinge door for a weatherproof seal. Stainless steel hardware.

### Optical System

Made for medium mounting heights ranging from 12' to 18'. Two piece pinged aluminum reflector. Meets Dark Sky requirements for full cutoff fixtures.

### Electrical System

Provided with a medium base 4KV pulse rated socket. Fixtures are available with up to 175W Metal Halide or 150W High Pressure Sodium light sources. Wall Packs come with an option of Multi-Tap (120V, 208V, 240V, 277V) or 480V high power factor ballasts.

### Mounting

Built in template for mounting to electrical boxes. Threaded 1/2" and 3/4" NPT knockouts provided on side and rear of fixture.

### Finish

A Super Durable Polyester powder coat finish is electrostatically applied. Standard colors available: Black, Bronze, White, OD Green, US Green. Custom colors available upon request.

## MWP SERIES MEDIUM WALL PACK

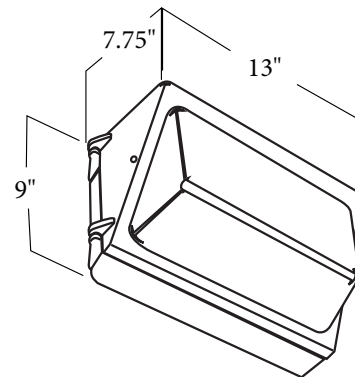

Est Shipping Weight: 18 lbs

Please contact your Techlight Sales Representative for more information.

### Ordering Nomenclature

Ex: (Medium Cutoff Wall Pack 150W Pulse Start Metal Halide, Multi-Tap, Bronze = MWPB9A-BZ)

MWP					
SERIES MWP	LIGHT SOURCE B1 = 70W PSMH B2 = 100W PSMH B3 = 175W MH B4 = 70W HPS B5 = 100W HPS B6 = 150W HPS B9 = 150W PSMH	VOLTAGE A = Multi-Tap B = 480V	PULSE-START PS = Pulse-Start	FINISH BK = BLACK BZ = BRONZE GR = OD GREEN WH = WHITE SP = SPECIAL	